

# **OPERATION & MAINTENANCE MANUAL**

for Vahterus Plate & Shell Heat Exchangers

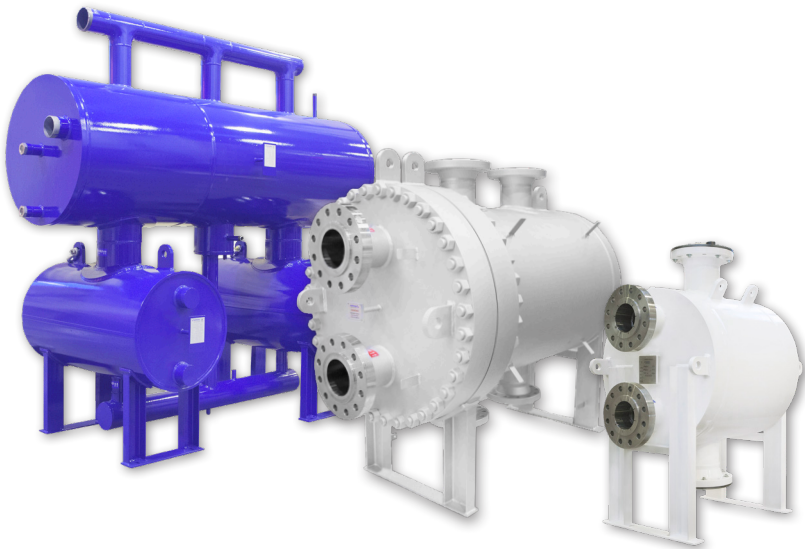

All rights reserved. It is not permitted to copy, photograph or publish in any other way this manual for any purpose without the permission of Vahterus Oy. Plate & Shell is registered trademarks of Vahterus Oy.

C303-3-rev.6 /16.4.2018

<b>1</b>	<b>GENERAL</b>	<b>5</b>
1.1	INTRODUCTION	5
1.2	PRODUCTS	5
1.3	STRUCTURE	6
1.4	TECHNICAL CHARACTERISTICS	6
<b>2</b>	<b>ASSEMBLY OF THE HEAT EXCHANGER</b>	<b>7</b>
2.1	LIFTING	7
2.2	PIPES	8
2.2.1	GENERAL	8
2.2.2	STEAM APPLICATIONS (CONDENSER)	9
2.3	INSULATION	10
2.4	PRESSURE TEST	10
2.5	MOUNTING BRACKETS	10
<b>3</b>	<b>PERMITTED CONDITIONS FOR OPERATING</b>	<b>10</b>
3.1	DESIGN	10
3.2	FLUIDS	11
3.3	FLOW RATES	12
<b>4</b>	<b>OPERATION</b>	<b>12</b>
4.1	PRINCIPLE OF THE HEAT EXCHANGER	12
4.1.1	LIQUID – LIQUID	13
4.1.2	CONDENSER	14
4.1.3	DX-EVAPORATOR	14
4.1.4	FLOODED EVAPORATOR	15
4.1.5	DROPLET SEPARATOR	15
4.1.6	STEAM GENERATOR (KETTLE)	16
4.1.7	EXHAUST GAS ECONOMICER (EGE)	16
4.2	GENERAL START-UP	16
4.3	GENERAL SHUT DOWN	17
4.4	START-UP AND SHUT DOWN OF STEAM APPLICATIONS	17
4.5	RECOMMENDED PERIODICAL INSPECTIONS OF PSHE HEAT EXCHANGERS	20
<b>5</b>	<b>CLEANING THE HEAT EXCHANGER</b>	<b>20</b>
5.1	GENERAL	20
5.2	RECOMMENDATIONS FOR CLEANING	21
5.2.1	BACKWARDS FLOW	21
5.2.2	CHEMICAL CLEANING	22
5.2.3	MECHANICAL CLEANING	23
5.2.4	ANALYZE AFTER CLEANING	23

5.3	OPENABLE MODEL .....	23
5.3.1	PREPARATIONS.....	23
5.3.2	OPENING THE EXCHANGER AND REMOVING THE PLATE PACK .....	24
5.3.3	MOUNTING THE PLATE PACK .....	25
5.3.4	BOLT/ NUT TIGHTENING PATTERN.....	25
<b>6</b>	<b>EXPANDABLE PLATE PACK .....</b>	<b>26</b>
<b>7</b>	<b>SPARE PARTS / SPECIAL TOOLS .....</b>	<b>26</b>
<b>8</b>	<b>PACKING AND STORAGE .....</b>	<b>26</b>
<b>9</b>	<b>TROUBLESHOOTING .....</b>	<b>28</b>
9.1	COMPLAINTS REPORT .....	30
9.2	MEASURES FOR REPLACEMENT .....	30
9.3	INFORMATION ABOUT THE REPAIR .....	30
9.4	CRITERIA OF LIMITING CONDITIONS FOR THE EQUIPMENT .....	30
<b>10</b>	<b>RECYCLING.....</b>	<b>31</b>

# 1 GENERAL

## 1.1 INTRODUCTION

Operating instructions of the Vahterus Plate & Shell Heat Exchangers (PSHE) contain Technical Data Sheet, Dimensional drawing and this Operation & Maintenance manual.

This manual is your general guide to the proper installation, operation and maintenance of the Vahterus Plate and Shell Heat Exchanger and PSHE droplet separator. Please read it and follow the instructions given. PSHE is a totally welded plate heat exchanger without any gaskets between the plates. Vahterus accepts no liability for damage caused through the incorrect installation, operation or maintenance of the unit.

## 1.2 PRODUCTS

### Plate & Shell Fully welded

Fully welded model – a welded pack of circular plates inside a welded pressure vessel. The applications for this type are liquid–liquid, condenser, evaporator and cascade. This model cannot be opened. This heat exchanger can be single or multi pass. (See Chapter 4.1.: Principle of heat exchanger)



### Plate & Shell Openable

Openable model. Fully welded plate pack inside an openable shell. The plate pack can be taken out of the shell.



### Plate & Shell Compact

All connections are on the end plate. Can be single or multi pass.



## Plate & Shell Combined

Heat exchanger with combined droplet separator.



## Plate & Shell VES

Heat exchanger with external droplet separator.



## Plate & Shell EGE

Exhaust gas economizer.

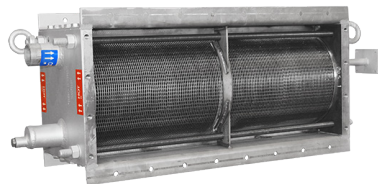

## 1.3 STRUCTURE

Vahterus Plate and Shell Heat Exchangers are designed and manufactured in compliance with legislation relating to pressure equipment.

The design code used is given on the Vahterus Technical Data sheet. The codes generally used are:

- ASME VIII Div.1, based on an individual design for each heat exchanger.
- Pressure Equipment Directive (CE): the design is based on PED classification and modules e.g. type approvals by NoBo.

## 1.4 TECHNICAL CHARACTERISTICS

General range of parameters:

Volume: from 0.0002 m<sup>3</sup> to 5 m<sup>3</sup>.

Temperature: from -196°C to +600°C.

Pressure:

- 10 / 16 / 25 / 40 / 60 bar(g) standard range
- up to 170 bar(g) on request

Materials:

- Carbon Steel (P235GH, P265GH, P355NL2, SA516Gr70, SA333 etc.)
- AISI 316/316L, 1.4404 / 304L, 1.4403
- Titanium Gr. 1
- Hastelloy (C22 & C276)
- Nickel 201
- SMO 254, EN 1.4547
- AISI 904, EN 1.4539
- Duplex, EN 1.4462
- other materials on request

Working mediums:

- Liquid of all groups
- Gas of all groups
- Steam (superheated & saturated) of all groups
- 2 phase mediums (i.e. liquid-gaseous mixture) of all groups
- Refrigerants group 1
  - R170 (ethane)
  - R1150 (ethylene)
  - R290 (propane)
  - R717 (ammonia)
  - R1270 (propylene)
- Refrigerants group 2
  - R134a
  - R744 (CO<sub>2</sub>)
  - R404a
  - R410a
  - R407F
  - R507a
  - all the other refrigerants from group 2

## 2 ASSEMBLY OF THE HEAT EXCHANGER

### 2.1 LIFTING

Plenty of space should be provided around the heat exchanger for mounting, insulation and maintenance. With the openable model, there should be available space equal to the total length at the front in order to remove the plate pack.

Ensure that there is adequate space above the heat exchanger in order to lift it freely.

The heat exchangers are provided with welded lifting lugs or lifting eye lugs. If lifting lugs are not assembled, lift the heat exchanger with textile belt around the shell.

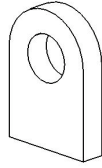

Lifting (eye) lug	Lifting force (direct lift)
1T (WELDED)	1,000 kg
3T (WELDED)	3,000 kg
5T (WELDED)	5,000 kg
7T (WELDED)	7,000 kg
M16 (DIN 582)	700 kg
M20 (DIN 582)	1,200 kg



### NB!

When heat exchangers are combined with droplet separators you should take account of their considerable overall weight and lifting gear and used lifting lugs are in the range. It is essential that the entire unit is supported by crane or hoist by the lifting lugs until it is bolted in position.

If necessary the combination can have permanent extra support by the lifting lugs in the surrounding support structures.

Do not use the mounting brackets or nozzles to lift the heat exchanger.

Vahterus will assist in planning of the liftings if needed, and separate lifting instructions are available at Vahterus. Please contact Vahterus Service.

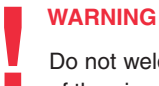

### WARNING

Do not weld anything to the heat exchanger (including the shell, end plates and the sides of the pipes) without the manufacturer's permission, since this could harm the durability of pressure envelope and internal structures of the heat exchanger.

## 2.2 PIPES

### 2.2.1 GENERAL

Install the unit so that the piping and heat exchanger can be drained easily.

The heat exchanger is not normally provided with separate drain and ventilation connections. If the client's process requires these, they should be installed in the pipelines as close as possible



to the heat exchanger, or, if they are being installed in the exchanger, they should be specified separately when the exchanger is being ordered.

Check the following:

1. All piping to be fixed to the exchanger is to be flushed prior to connecting the unit.
2. All connections are marked and should be connected according to the GA drawing.
3. The piping system must be flexible so that thermal expansion does not overload the nozzles and so that heat exchanger is not subjected to vibration.
4. All pipe connections to and from the heat exchanger must be equipped with shut-off valves. It is recommended to use valves with slow valve action. It should be possible to increase flow rates gradually and reduce them gradually when the system is being shut down or start up.
5. If there are solids in the process fluids, the use of filters is recommended. Further information is available from Vahterus Service.
6. The piping must be equipped with a relief valve to prevent unintentional excess of design pressure.
7. If multiple units are being arranged in parallel, you should ensure that flow is evenly distributed to the exchangers.

### Openable model

Connections between the plate pack on the openable model and the pipes must be made either with flange or threaded connections.

## 2.2.2 STEAM APPLICATIONS (CONDENSER)

The pipelines should be manufactured according to good steam flow manufacturing practices.

In steam applications the unit is placed horizontally to prevent condensate from remaining on the surface of the plates.

It is recommended, where necessary, to install a steam trap (drain) in front of and behind the heat exchanger and a droplet separator in front of it. The separators in front of the exchanger are installed before the valve. These will prevent condensate from accumulating behind the valve.

When the water vapour is on the shell side, the heat exchanger is provided with a striker plate, which is welded to the HOT IN connection to prevent water hammer. However, the customer should also try other ways to prevent water hammer in the heat exchanger.

### **WARNING**

When the valve is closed, condensate might accumulate in the steam pipeline if no attention has been paid to drainage. When the valve is opened, accumulated water passes into the heat exchanger at high speed, possibly resulting in mechanical damage.

### **NB!**

If the exchanger is operating in a partial vacuum or where the pressure on the steam side is able in some cases to lower the pressure on the condensate side, the use of a condensate pump should be considered.

When a condensate side control is being used, the condensation temperature on the hot side must not be any higher than the evaporating temperature on the cold side; e.g. if there is water on the cold side, the pressure of the steam must be lower than the pressure of the water, to prevent the water from boiling.

## 2.3 INSULATION

If the temperature on the shell side is below  $-10^{\circ}\text{C}$  or above  $65^{\circ}\text{C}$ , insulation is recommended to avoid burns or frostbite.

## 2.4 PRESSURE TEST

All PSHE units have been pressure-tested, as follows:

- a) all plate packs – leak test (pneumatic pressure test under water)
- b) whole unit – pressure test (hydraulic pressure test)

If you need to perform a pressure test prior to using the heat exchanger, the test pressure is given on the Technical Data sheet and on the nameplate. The pressure shall increased slowly to prevent pressure shocks. During manufacturing in certain cases the water as pressurizing media is not acceptable for the media (refrigerant or oils) in the user's process, the pressure test is waived and made additional NDT to the welds.



**NB!**

Pressure testing of the plate pack in the openable heat exchanger should always be carried out with the plate pack positioned in the shell and the bolts on the cover plate tightened, in accordance with the instructions in this manual.

When pneumatic leak or pressure testing is being carried out, ensure that conditions are safe, given the possibility that there could be a pressure discharge similar to an explosion should the heat exchanger or testing equipment get broken.

**Never apply pressure to the plate pack outside the shell.**

## 2.5 MOUNTING BRACKETS

Vahterus standard brackets are only designed to bear the weight of the heat exchanger. The design does not allow for specific requirements, such as stress and strain caused by the piping, wind load or earthquakes.

# 3 PERMITTED CONDITIONS FOR OPERATING

## 3.1 DESIGN

The design pressures and temperatures are marked on the nameplate and Technical Data sheet.

Never exceed the design pressures or temperatures. Ambient temperatures may not be higher/lower than the design temperature range.

Environmental load, load on connections caused by the piping, wind load and earthquakes are not taken account of in the (design) strength calculations, unless mentioned separately.

The pipework in the heat exchanger and the mounting brackets must not be loaded down by external forces, unless mentioned separately in the strength calculations.

Corrosion allowance is indicated in the strength calculations: for carbon steel it is at least 1 mm. Any greater corrosion allowance requirement must be stated when the heat exchanger is being ordered.

Fatigue: 500 full pressure cycles allowed without separate calculations. If this number is exceeded, the customer should test the heat exchanger (pressure test and possible NDE tests) with reference to local laws.

Possible risk of external fire: the customer should advise the manufacturer.

Safety appliances should be specified/designed and acquired by the customer, as they are not provided by Vahterus Oy.

## 3.2 FLUIDS

The structural materials are selected based on the information (media, temperatures, flows) provided by the customer. You can also contact Vahterus for material and flow director material options.

If the heat exchanger is used in conditions that differ from what it has been designed for (technical data sheet), its ability to function needs to be checked. For example, if the viscosity of the fluid varies according to conditions and differs from the information on the Technical Data sheet and could result in a difference in pressure of more than 200 kPa between the exchanger and the incoming and outgoing connectors, Vahterus should be contacted to re-assess the load situation.

When the customer approves the heat exchanger materials, he needs to ensure that they will stand up to the conditions they will be subjected to during his process. Acid-resistant steel is even prone to forms of corrosion, e.g. intergranular corrosion, pitting corrosion, stress corrosion and biological corrosion. The chloride content of water can cause corrosion in AISI 316L/ 1.4404 plate materials in a short space of time. When water is boiling, in particular, it causes chloride precipitation and this can lead to corrosion at quite small concentrations.

Other factors causing a risk of corrosion are pH, the liquid's flow rate, dirt on the plate, impurities, etc., whose effect should be assessed for each individual process. If there is a risk of corrosion, more durable materials such as AISI 904L, SMO 254, Duplex or titanium should be considered.



### **NB!**

For special instructions regarding the quality of water in steam generators, contact Vahterus Sales. The customer should inform the manufacturer if unstable fluids are used in the process.

### General recommendation for water quality when AISI 316L plate material is used in +20 °C.

Variable	Unit	Recommended quality limits for water for AISI 316L
Hydrogen ion concentration	pH	6-9
Alkalinity (as CaO <sub>3</sub> )	mg/l	< 300
Chloride	mg/l	< 500 mg/l at 25°C < 200 mg/l at 50°C < 60 mg/l at 80°C 0 mg/l, when T > 100°C
Sulphate	mg/l	< 100
KMnO <sub>4</sub> - consumption	mg/kg	< 20
Aluminium	mg/l	< 0,3
Iron (Fe)	mg/l	< 0,3
Manganese	mg/l	< 0,1
Sodium + Potassium	mg/l	< 200
Conductivity	mS/m	< 200
Calcium	mg/l	< 20

## 3.3 FLOW RATES

Flow rates should be kept as near as possible to the design values. Lower flow rates can cause unexpected changes to the heat exchanger and make the plate surfaces dirty. If you want to use a heat exchanger with essentially greater flow rates, the suitability of the exchanger should be checked with the manufacturer.

# 4 OPERATION

## 4.1 PRINCIPLE OF THE HEAT EXCHANGER

The purpose of a heat exchanger is to transfer heat from one to another flow of fluid via a corrugated heat transfer plate.

The construction is such that the flows alternate through the plate pack. The flows can be controlled as counter-current, co-current or cross-flow.

## Structure of the Vahterus Plate and Shell® heat exchanger:

The plate and shell® heat exchanger consists of circular plates welded into a pack, which is then mounted in a pressure vessel.

The flow on the plate side is through the connections on the end plates via the plate pack.

The flow on the shell side is through the shell connections via the plate pack using a flow director.

The construction may be either fully welded or openable. The openable type has a removable cover plate so that the plate pack can be removed, to clean it, for example.

**These are the various applications of a PSHE exchanger:**

### 4.1.1 LIQUID – LIQUID

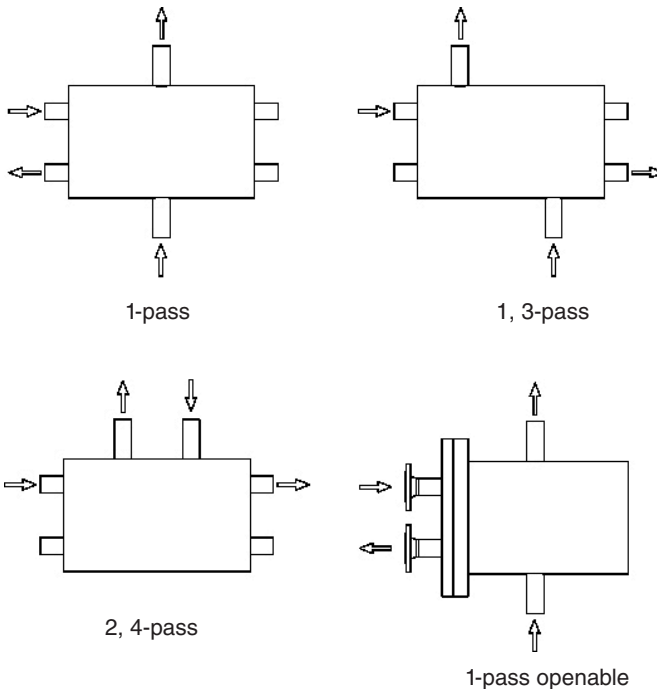

In liquid - liquid applications, the hot and cold sides can be mounted to either side of the exchanger. In general, the hot side would be on the plate side and the cold liquid on the shell side. The hot and cold sides are clearly marked on the drawings and heat exchangers.

General recommendation for flow directions are hot side down and cold side up, however special directions can be stated during heat exchanger heat transfer calculation.

### 4.1.2 CONDENSER

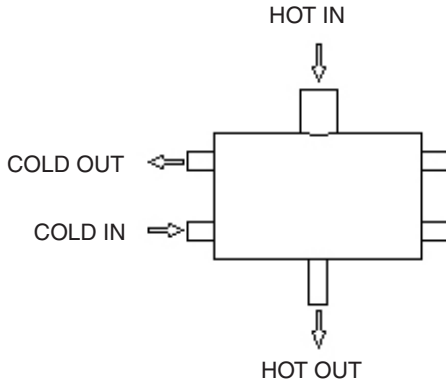

In condensing applications, the steam is on the shell side, with the cold side on the plate side. Shell side (steam) flow enters the exchanger at the top of the shell and the condensate exits at the bottom. Plate side flow is counter-current: the exchanger is operating on the counter-current principle. Steam on the end plate side/cold side in the shell and vent condenser designs are also possible.

### 4.1.3 DX-EVAPORATOR

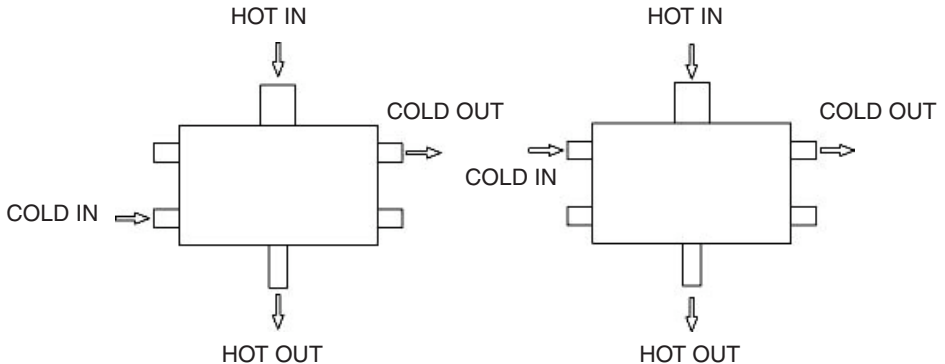

Evaporation always takes place on the plate side and cooling on the shell side.

#### 4.1.4 FLOODED EVAPORATOR

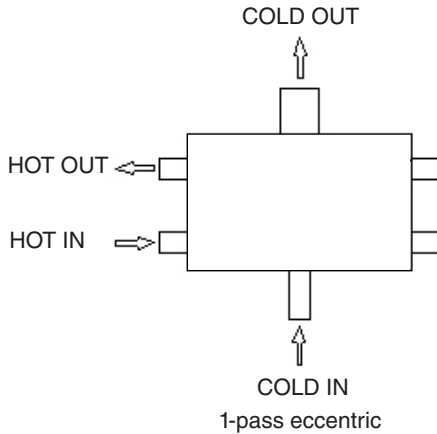

Evaporation generally takes place on the shell side. With special applications, however, it can take place on the pack side.

#### 4.1.5 DROPLET SEPARATOR

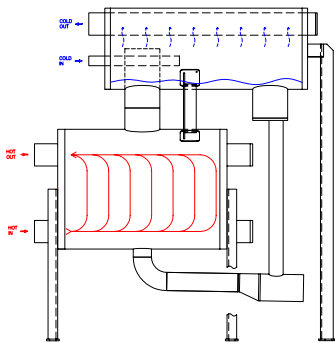

The heat exchanger system is the same as in 4.1.4, with the addition of a droplet separator and recirculation pipe.

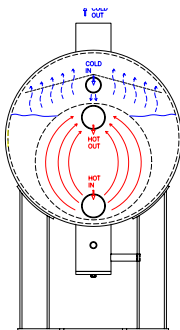

In the combined heat exchanger the droplet separator is integrated with the exchanger's shell.

#### 4.1.6 STEAM GENERATOR (KETTLE)

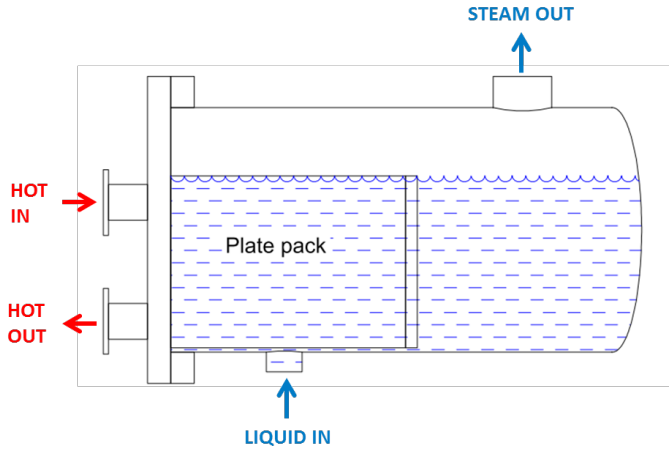
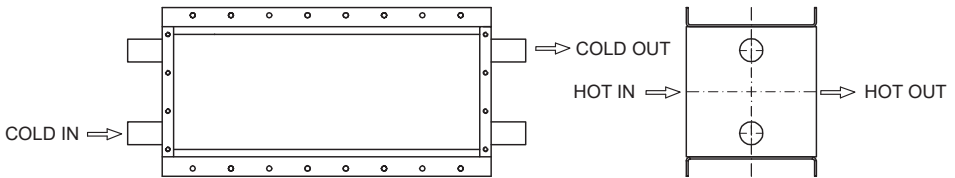

Plate pack positioned in large shell. Steam generator application.

#### 4.1.7 EXHAUST GAS ECONOMICER (EGE)



For cooling or heating gases.

### 4.2 GENERAL START-UP

Following instructions are general and process specific demands have to take in count by the user.

Check the following before start-up:

- Pipe connections comply with the drawings and are properly supported/fastened.
- Drain valves are closed.
- The Heat Exchanger and pipelines are properly vented.
- Any safety appliances are properly connected.
- There are no risk factors in the pipes that could cause shock pressure (water hammer) or sudden changes in pressure.

First start the flow on the cold side, and then start and gradually increase the flow on the hot side. However if there is a risk of freezing or the liquid being used has high viscosity the start up sequency has to check and determine by the user according to process requirements.



General heating rate is max. 5°C/minute.

The pressure may be increased to operating gradually. See also section 3.2.

Check system for pressure pulses caused by pumps or controls valves. Continuous pulsing and vibration may cause fatigue in the plates.

To start the heat exchanger process, follow steps a–f, starting first on the cold side. Then repeat for the hot side.

- a) Close the inlet shut-off valve.
- b) Open the outlet shut-off valve.
- c) Open the vent valve, if the heat exchanger is provided with one; otherwise vent from the nearest vent valve to the heat exchanger in the pipework.
- d) Start the pump.
- e) Slowly open the inlet valve according to the instructions.
- f) Close the vent valve when all the air has been removed from the system.

If the heat exchanger is working properly it can be used on an ongoing basis.

### Openable model

When the openable model is being started up, always check the bolts and tighten them if necessary.

## 4.3 GENERAL SHUT DOWN

If the heat exchanger process is to be halted, follow steps a-d below, starting first on the hot side. Then repeat for the cold side.

- a) Slowly close the inlet valves.
- b) Switch off the pumps.
- c) Close the outlet valves.
- d) Drain and vent the heat exchanger.

**Gradually decrease the flow on the hot side until it stops completely. Then close the cold side.**



### NB!

Valves must be set to open gradually. Sudden opening and closing of the valves will subject the exchanger to thermal shock and may cause material fatigue.

In steam applications, never leave hot side on when the liquid side is turned off. Turn the steam OFF first and ON last.

In steam process it must be noted that cooling water side pressure must be higher than steam pressure in condensate side controlled unit. If pressure is lower, cooling water can evaporate and there is a risk for plate damage.

## 4.4 START-UP AND SHUT DOWN OF STEAM APPLICATIONS

It is necessary to vent air off from the heat exchanger before starting the operation. The following procedure can be followed:

## Air venting process

1. Close the inlet shut-off valve
2. Open the outlet shut-off valve
3. Open the vent valve, if the heat exchanger is provided with one: otherwise vent from the nearest vent valve to the heat exchanger in the pipeline
4. Start up the pump
5. Slowly open the inlet valve according to the instructions.
6. Close the vent valve when all the air has been removed from the system
7. Start the actual start-up procedure

After the venting procedure, please check the additional information for different units.

### Steam condenser with steam side control:

Be aware! If cold side flow is turn fully on before opening the steam valve, steam side start-up will lead to vacuum condition when starting up.

1. Partly open the cooling water side. All valve openings must be made gradually to prevent thermal shocks to the heat exchangers.
2. Check that the heat exchanger and steam lines are empty of condensate if the system is steam side controlled. Also the condensate outlet pipe needs to be empty from condensate. To be able to have safety start-up, good condensate level control in the system is recommended.
3. Open steam valve gradually allowing condensing to start. The temperature increase has to be done step by step, max. 20°C/step and then let it stabilize (the temperature increasing rate at start-up is max. 5°C/minute). The temperature is increased by increasing steam pressure.
4. If the unit is cold (below 0°C), the correct heating rate is 100°C/hour for the first 100°C. After that, the heating rate can be according to the position 3.
5. Full capacity is reached by opening the both side gradually to full open position.

### Steam condenser with condensate side control:

1. Unit steam side needs to be filled with water when starting up the unit
2. Check that the steam lines are empty of condensate
3. Open the cooling water side partly. Valves must be opened gradually to prevent thermal shocks to the heat exchangers.
4. Open steam condensate valve gradually allowing condensing to start. The temperature increase has to be done step by step, max. 20°C/step and then let it stabilize (the temperature increasing rate at start-up is max. 5°C/minute). The temperature is increased with increasing pressure. The steam side pressure must always be lower than the cooling side pressure. (Figure 1 and 2)
5. If the unit is cold (below 0°C), the correct heating rate is 100°C/hour for the first 100°C. After that, the heating rate can be according to the position 3.

#### ATTENTION!

- It is not possible to measure the condensate level over the Vahterus PSHE unit
- In condensate controlled units, the capacity control is made by controlling the condensate level inside the unit according to the cold side outlet temperature. Condensate tempera-

ture cannot be used to control the condensate level inside the unit.

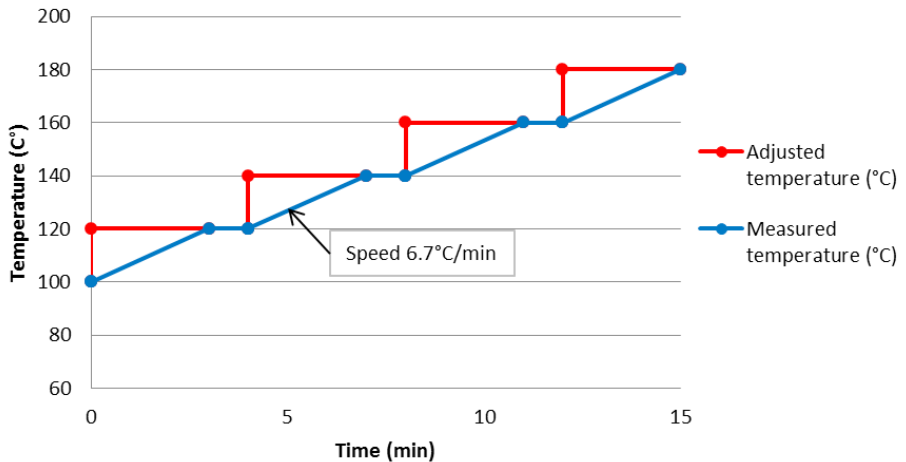

**Fig. 1.** When the rate of temperature increase is higher than 5°C/minute, the time between the incremental steps has to be taken into account.

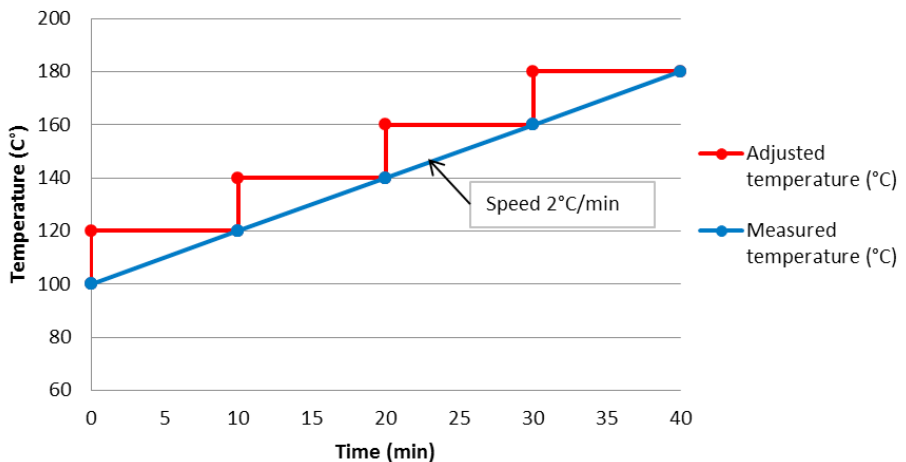

**Fig. 2.** When the rate of temperature increase is lower than 5°C/minute, the temperature can be increased immediately after it has reached the adjusted temperature.

### Steam generator:

1. Check that the heat exchanger cold side is flooded with the condensate before opening the secondary side flow.
2. First, open the hot side to start heating up. Open the valve gradually to prevent thermal

shocks.

3. Open inlet valve of the primary side allowing liquid to enter the generator. After that, open the outlet valve (start-up valve if any).
4. If the unit is cold. The correct heating speed is 100°C/hour for the first 100°C. After that the heating rate can be doubled.
5. Gradually open more the hot/cold side valves to reach the required capacity.

### Shut down

If the process is to be stopped, follow the steps below. Begin shutting down the hot side following the steps below, then repeat the same for the cold side.

1. Slowly close the inlet valves. Gradually decrease the flow until it stops completely.
2. Switch off the pumps
3. Close the outlet valve
4. Drain and vent the heat exchanger

## 4.5 RECOMMENDED PERIODICAL INSPECTIONS OF PSHE HEAT EXCHANGERS

### Fully welded heat exchangers:

Inspection period 5 years

- Internal inspection of shell chamber with endoscope

Inspection period 10 years

- Pressure test

### Openable heat exchangers:

Inspection period 5 years

- Internal inspection of shell chamber with endoscope

Inspection period 10 years

- Pressure test
- Internal inspection by opening the unit
- Visual check of shell chamber and plate pack

The user of the heat exchanger shall check local requirements for pressure vessel inspections. The inspection periods shall be re-evaluated by the inspector after every inspection according to the findings and shortened if necessary.

## 5 CLEANING THE HEAT EXCHANGER

### 5.1 GENERAL

The rules and requirements for cleaning a heat exchanger vary from type to type. If there is a risk of fouling, the unit's performance should be monitored by measuring temperature and pressure loss. When losses are greater than permitted, the heat exchanger should be cleaned.

## 5.2 RECOMMENDATIONS FOR CLEANING

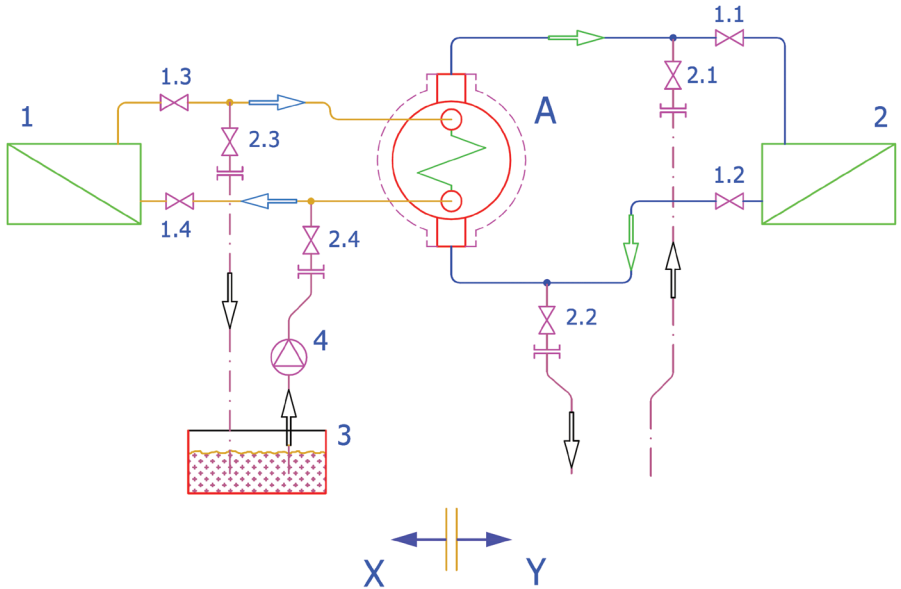

X = cleaning with chemicals

Y = cleaning with backwards flow

A = Vaherus heat exchanger

1.1 – 1.4 = system shut off valves

2.1 – 2.4 = shut off valves for cleaning

1 – 2 = heat or cold users or suppliers

3 = circulating tank

4 = pump for chemicals

**Fig. 3 Cleaning methods**

### 5.2.1 BACKWARDS FLOW

In most cases loose materials as organic compounds, gathered on the surface of the plates, can be removed by inverting the flow or with back flow washing with warm water or cleaning medium. Warm water or cleaning medium is flushed with high speed on the primary and/or secondary side in the opposite direction than during the normal operation (velocity approx. 2-3 times the normal velocity). The valves in the connection pipes must be closed and the drain valves mounted on the pipelines opened. The dirty medium must be discharged and disposed in accordance with local requirements.

#### Description of the backwards flow system:

- Close valves 1.1 and 1.2. Temperature of the heat exchanger must be between 10°C and 30°C.
- Drain off the liquid from the primary or secondary side, the side that must be cleaned, by opening valve 2.2.
- Connect a hose to valve 2.1.
- During 10-15 minutes water should flow through the heat exchanger.

- Check that organic compounds and dirt are removed.
- Stop the water flow, close valve 2.1.
- Fill the heat exchanger with system liquid in accordance with the mentioned start-up procedure, close valve 2.2.

If it is impossible or insufficient to clean the surface in this way a specific detergent should be used.

## 5.2.2 CHEMICAL CLEANING

A chemical cleaning company experienced in cleaning of plate heat exchangers is recommended to use with chemical cleaning. The cleaning process should involve the use of common cleaning agent brands, which normally contain additives that make for more effective cleaning and prevent corrosion. In order to achieve a good cleaning result, the cleaning agent is to be chosen based on the dirt and impurities in the process and/or heat exchanger. The use of unsuitable cleaning agent may result in worsening of the impurity problem.

### REMARKS:

- Before cleaning the heat exchanger with chemicals check the resistance of all materials to that chemical.
- After chemical treatment the plates absolutely must be rinsed carefully with clean water.
- When during cleaning on the coolant side a high temperature can occur in the heat exchanger be sure that the pressure on the refrigerant side will not increase too high.
- Before cleaning remove the refrigerant or be sure the refrigerant side is not trapped.

### Example of the procedure to clean the secondary side with chemicals:

1. Close the valves 1.3 and 1.4. The temperature of the heat exchanger should be between 10°C and 30°C.
2. Connect the hoses of the cleaning system with chemicals to the valves 2.3 and 2.4.
3. Fill the tank with the chemical solution.
4. Switch on the pump (4) and let the pump run during 30-40 minutes. Check during cleaning at certain intervals the concentration and activity of the chemicals on inlet and outlet side of the heat exchanger. Stop cleaning if there is no changing anymore.
5. If dirt has been removed, drain the chemicals from the heat exchanger and the tank, neutralize applied chemicals.
6. Wash the plate surface with clean water in back flow.
7. Take the heat exchanger in normal operation as described in part 6.

It may be necessary to clean the surface with chemicals more as once.

Handle chemicals and dirt in accordance with the safety-, environmental-, governmental regulations and laws.

### WARNING

Before cleaning, check that the solution is suitable for the flow director material. The material is mentioned on the heat exchanger's data sheet.

### 5.2.3 MECHANICAL CLEANING

Openable and EGE models is possible to clean mechanically by high pressure water jet with cold or hot water. Contact Vahterus for further information.



#### **WARNING**

The high pressure water jet may compress the dirt and impurities into the plate gaps and block the flow passages.

### 5.2.4 ANALYZE AFTER CLEANING

Analyze if appeared pollution might be avoided by:

- Installing strainers
- Degreasing temperatures (installing desuperheater)
- Increasing system pressure
- Refreshing the medium more or in shorter intervals
- Bring the medium in right concentration
- Increase the flow between the plates
- Changing the capacity control into a system with constant flow

## 5.3 OPENABLE MODEL

The plate pack in openable heat exchangers can be taken out of the shell and cleaned using a high pressure cleaner. When removing the plate pack follow these instructions in order to avoid damaging the plate pack and flow directors.



#### **WARNING**

Never apply pressure to the plate pack outside the shell. The plate pack's support structures are not designed to withstand forces resulting from pressure exerted on it and so the application of pressure may well cause an accident.

### 5.3.1 PREPARATIONS

It is recommended to move the unit somewhere sufficiently spacious in order to carry out any required service or maintenance. Drain the exchanger on both the plate and shell sides and open all the pipe connections before moving the unit. If the exchanger cannot be moved, only open the connection pipes on the plate side and ensure that there is enough room in front of it to remove the plate pack (the minimum space needed is the entire length of the exchanger).

When removing the plate pack from the shell, measure the pack length from gasket surface to the end of the pack, and respectively the shell length from the gasket surface to the end plate. The plate pack must be supported by the end plate when installed in the shell. If the plate pack is replaced, measure the shell to ensure the fit of the new plate pack. See section 9.2.

### 5.3.2 OPENING THE EXCHANGER AND REMOVING THE PLATE PACK

#### Option 1 (recommended)

Move the unit to a more spacious area and turn it so that the end plate connections are facing upwards (plate pack vertical).

Remove some of the bolts from the cover plate and install guide bars (4-6) in the bolt holes before removing the remainder of the bolts. Remember to mark the position of the cover plate relative to the shell to ensure that the plate pack is put back in the same position!

**The plate pack is fastened to the cover plate. Pull the cover plate carefully out from the shell using the lifting lugs and try to protect the flow directors.**

**!** Ensure that the exchanger is supported properly and that it remains stable and upright while service and maintenance are being carried out.

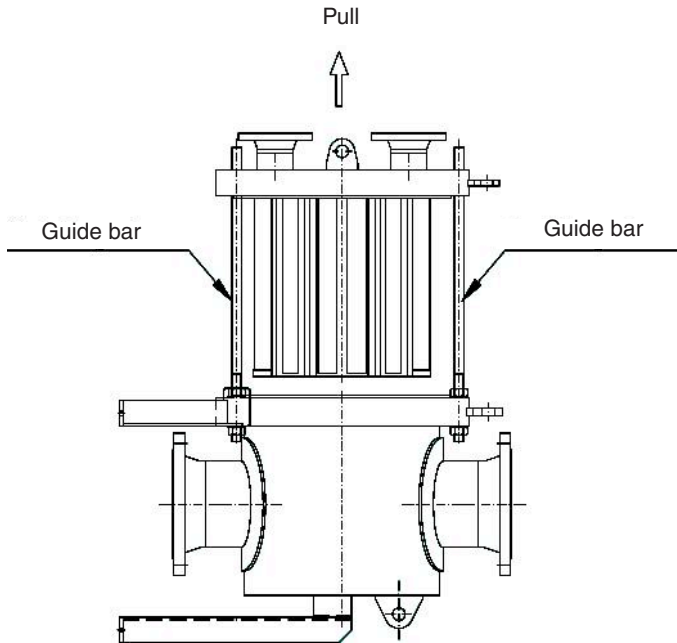

Fig. 4.

#### Option 2

When pulling the plate pack out, keep it horizontal, if necessary by using lifting straps. Place the straps in the lifting lugs on the blind flange. When the plate pack is almost entirely out of the shell, place two wooden blocks under the plate pack to protect the flow directors. Place the lifting straps in such a way that they support the plate pack, as in Figure 5.



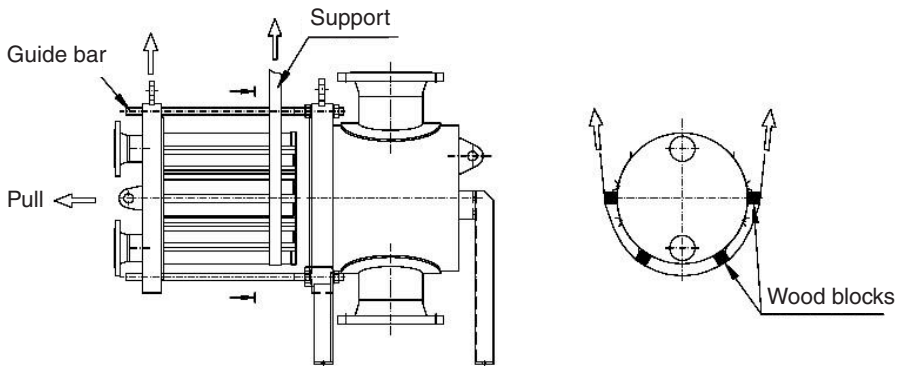

Fig. 5.

### 5.3.3 MOUNTING THE PLATE PACK

Before reinstalling the plate pack, the flow directors must be checked and corrected if necessary. If the flow director rubbers are damaged and need replacing, contact the manufacturer.

Change the gasket between the cover plate and flange; details of the gasket can be found on the Technical Data sheet.

Use the guide bars to ensure that the plate pack is repositioned successfully and safely. Check the position of the plate pack relative to the shell.

Lubricate the flow director rubbers with vegetable oil, for example, to facilitate repositioning.

When the plate pack is being mounted in the shell, the position of the flow directors must be checked continuously.

### 5.3.4 BOLT/ NUT TIGHTENING PATTERN

When tightening bolts, **never** use an impact tool. It is important to tighten the bolts to the same torque value. Always use a torque wrench or other calibrated tightening tool.

The sequence in which the bolts are tightened has a substantial bearing upon the distribution of the pressure on the gasket. Improper bolting may move the flange out of alignment. A gasket will usually allow for a small amount of distortion of this kind. Always tighten the bolts in a cross bolt tightening pattern. See the drawing, where the sequence is numbered.

Always screw in the nut or bolt by hand. This ensures that the thread remains in satisfacto-

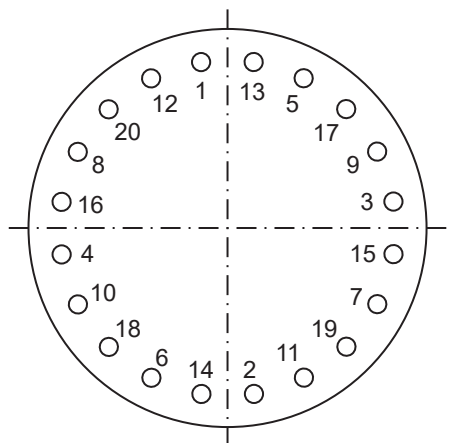

ry condition (if the nut will not screw in by hand, check the thread, replace damaged parts and start again).

Tighten the connections using a minimum of 5 revolutions, following the sequence. The following procedure is recommended:

**Revolution 1** – Tighten the start of the nut by hand following the sequence, after which tighten all of them by hand evenly.

**Revolution 2** – Using a torque wrench, tighten the bolts, following the sequence. Use a maximum of 30% of the eventual tightening torque. Check the position of the gasket between the cover plate and flange.

**Revolution 3** – Tighten using 60% of the eventual torque, following the sequence

**Revolution 4** – Tighten to full torque in a clockwise direction.

The tightening torque on lubricated bolts is stated in the GA drawing supplied with the exchanger.

## 6 EXPANDABLE PLATE PACK

An openable pack model may be expandable to facilitate the cleaning of the pack, for which separate instructions are available. Contact Vahterus for further information.

## 7 SPARE PARTS / SPECIAL TOOLS

Openable heat exchanger

- Flow directors
- Plate pack
- Gasket between the cover plate and flange
- Guide bars

These parts can be supplied when the exchanger serial number is provided.

## 8 PACKING AND STORAGE

The equipment is supplied checked and packed on site of manufacturing. After the delivery the personnel must check that the packaging and equipment were not damaged during transportation, check for any damages to external surfaces and the integrity and seals of temporary flanged connection closures. If any damage were found please register it and contact the transport company who is responsible for the shipment and the manufacturer.

Each heat exchanger leaves the factory in sturdy wooden box. The boxes are made from Finnish pine harvested in a sustainable forest.



**Fig. 6. Standard packing**

The wood is free from quarantine pests and practically free from other injurious pests. The wood is ISPM15 compliant and supplied with the following saw-mill stamp.

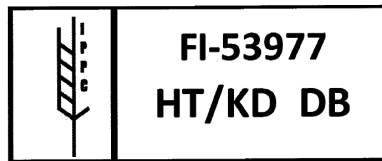

**Fig. 7. IPPC-stamp for wooden boxes. The packing materials are recyclable into energy or other purposes.**

Outdoor storage is not recommended.

Heat exchangers must be stored indoor and covered (if needed) for higher protection against dust, with temperature from +1°C to +40°C and relative humidity up to 90%.

Ensure that no liquids, dust, etc. enter the equipment during storage.

The equipment must be stored in an area free from construction activities and vehicle transit that could cause accidental damages.

The equipment must not be in contact with the ground.

Adequate free space must be foreseen around equipment to guarantee periodic inspections and free movement around the equipment.

Information about assigned parameters: assigned storage period, assigned service life.

Assigned storage period is 12 months.

Long term storage period (5 years) is possible, if the equipment is ordered by customer with nitrogen filling.

Upon the expiry of periods of the assigned parameters (assigned storage period, assigned service life) operation of the equipment is stopped, equipment is inspected, repaired (if necessary) and new assigned parameters are established (assigned service life and (or) assigned storage period). If the repair is not possible (or not reasonable) the equipment is disposed.

## 9 TROUBLESHOOTING

If the heat exchanger is not working properly after start-up, check the following:

PROBLEM	CAUSE	CHECKS	ACTION	NB!
Poor performance	Exchanger/connections connected wrongly.	Check flow directions of connections. Do they comply with the design/drawing?	Change the piping connections. Change direction of flow.	
	Pressure	Check pressure and temperatures on both sides.	Correct or adjust valves.	Contact the manufacturer and advise the following values: pressures, pressure differences, temperatures and flow rates.
	Pressure difference	Measure flow rates and pressure difference.		
	Temperature	Compare these values to the PSHE's thermotechnical data sheet.		
	Liquid flow	Check pump operation.	Change pump.	
Very poor performance and low pressure difference.	Flow director damaged by pressure shock or unsuitable process fluid.	Check the information on the name plate: are the temperature, and liquids correct? Check the process data if it is available.	Contact the manufacturer.	
External leakage between cover plate and flange (openable model)	Leaking gasket.	Look for leak.	Tighten bolts. If retightening does not stop the leak, remove cover plate and change gasket.	The Technical Data sheet contains details of the gasket. See tightening torque in section 5.1.

PROBLEM	CAUSE	CHECKS	ACTION	NB!
Internal leak (fluid mix)	Plate cracked due to water hammer or thermal shock.	Check that plate side liquid is visible on shell side (leaking fluid will be visible on the outlet pipe).	Contact the manufacturer.	
	Hole in plate due to corrosion.	Close plate or shell side valves and use a meter to see if the pressure is falling.		
	Pressure shock	Check the process data, if available.	Contact the manufacturer.	
	Mechanical wearing	Pressurise shell and find leak. Localise leak e.g. with colouring agent.	Contact the manufacturer.	
Very poor performance and very high pressure difference.	Shell or plate side channels clogged with accumulation of debris or scale.	Measure pressure loss throughout on both sides carefully to check the actual cause of the problem.	Clean exchanger according to instructions (section 5).	Run scheduled maintenance/ check work plan.
	Filter clogged.	Open filter and check its condition.	Clean/change filter.	
	Valve and process controls.	Check operation of valves.	Take necessary action: open, adjust or change.	
Gradual decline in heat transfer performance.	Slow build-up of impurities on plate surfaces on the plate or shell side.	Remove the plate pack (openable model) and examine the heat transfer surfaces. Welded models can be checked using an endoscope, if possible. If the shell side is clean, fouling of the plate side is responsible for the retardation of heat transfer.	Clean exchanger according to instructions (section 5). Replace gasket and plate pack (openable model).	Run scheduled maintenance/ check work plan.

If, after checking, the heat transfer capacity and or pressure loss are at an unacceptable level, contact your Vahterus representative.

## 9.1 COMPLAINTS REPORT

If you need to complain about a Vahterus product, ask for a notification of defect report at [sales@vahterus.com](mailto:sales@vahterus.com)

Please include as many details as possible, and especially the following:

- General information (serial number)
- Design and operation
- Type of problem and observations
- Status of process

When you have completed the report contact the Vahterus representative.

## 9.2 MEASURES FOR REPLACEMENT

If there is a need to replace a plate pack for an openable heat exchanger, take the measurements at four different points inside the shell – see diagram below.

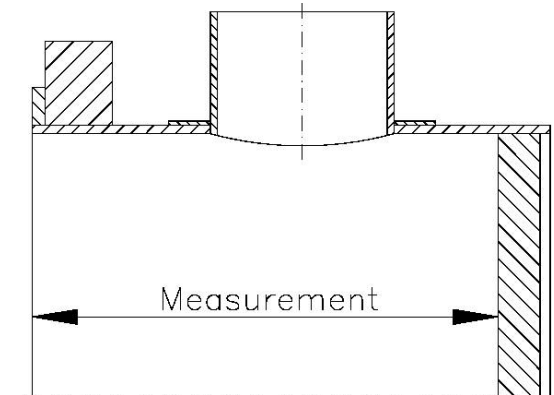

## 9.3 INFORMATION ABOUT THE REPAIR

The repair must be performed by a qualified organization under the full responsibility of the User, according to rules, which are in force in the country of the User, and original design drawings. If necessary, please contact Vahterus for more information.

## 9.4 CRITERIA OF LIMITING CONDITIONS FOR THE EQUIPMENT

- The mechanical wear (abrasion), scratches, corrosion damage with depth over the value of corrosion allowance for the wall thickness provided in the strength calculation.
- The mechanical damage of the plates, which cause mediums mixture.
- Dents, ovality, wear of equipment (or elements) over permissible values.
- Cracks and all kinds and directions.
- Defects in welds more than acceptable values, including single slag and gas inclusions depth and length more allowable values.

- 
- Corrosion cracking of the metal in the zone of welds, as well as in the field of corrosion pits.
  - Damage to the gaskets of flange connections or weakening of bolting.

## **10 RECYCLING**

The metals from the heat exchangers are recyclable, for example to make steel. The rubber from flow directors are not recyclable and they are to be disposed of according to local waste disposal regulations.

## CE and SAFETY

Before a Vahterus heat exchanger may be put into operation the contractor or customer must be sure that:

- Sufficient safety valves are installed and adequate safety measurements are taken into account.
- A plate stack or plate insert of an openable unit never may be pressurised outside the shell.
- Sufficient measurements are taken into account to prevent against possible corrosion of the pressure vessel particularly under the insulation.

ORGANISATION  
CERTIFIED BY

**Inspecta**

ISO 9001

ISO 3834-2

ISO 14001

OHSAS 18001



### **Vahterus Oy**

Pruukintie 7

FI-23600 Kalanti

Finland

Tel. +358 (0)2 840 70

sales@vahterus.com

[www.vahterus.com](http://www.vahterus.com)

